

FA 35 FA 35.2

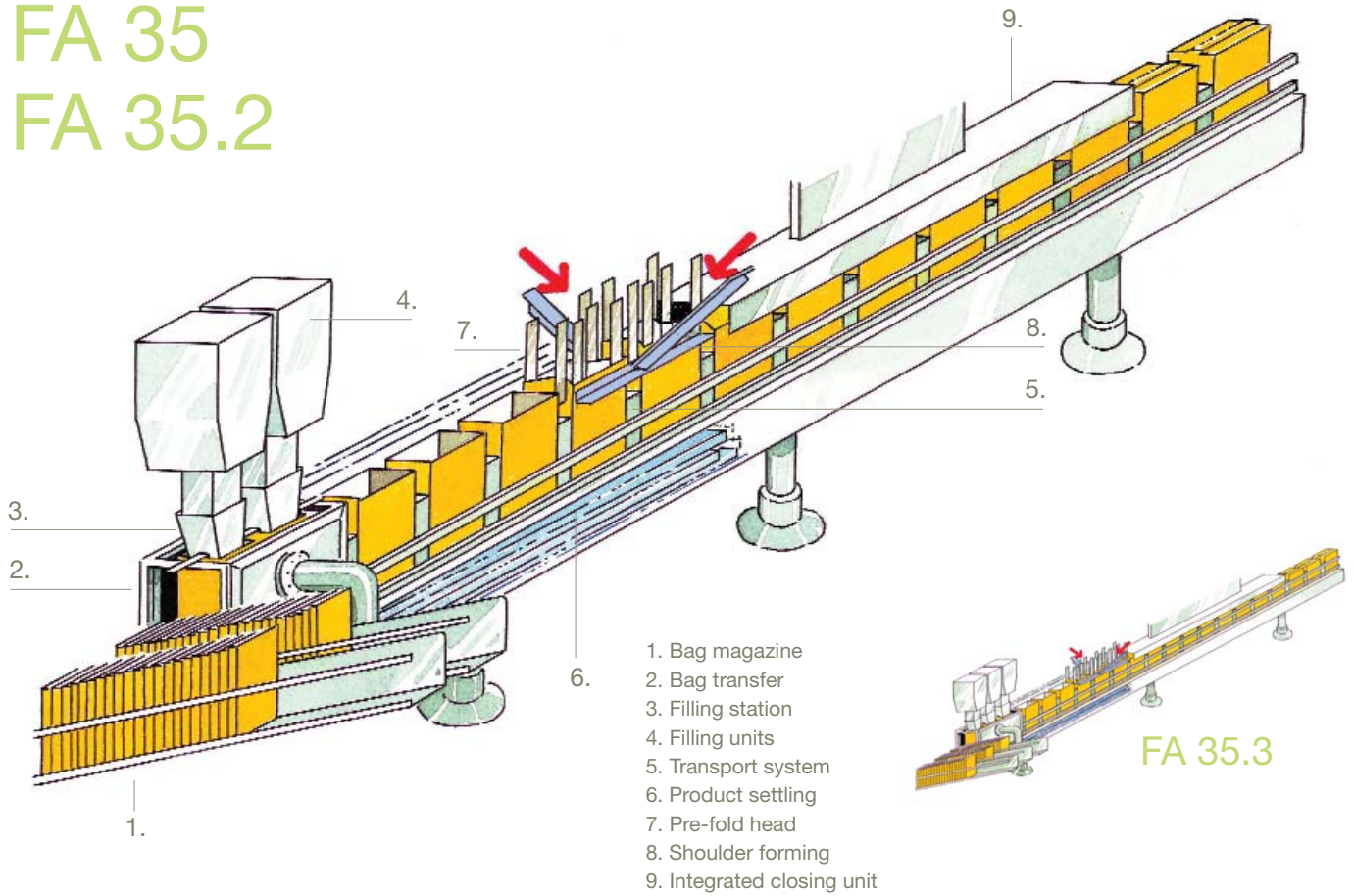

Pre-folding-station



Crease- and cutting-station



Large twin-bag magazine

Flexible and fast ...

High availability, maximum output together with optimum quality of the package for your products - these are the core criteria for packaging machines. The method of handling 1, 2 or 3 bags per machine cycle makes it possible to achieve a high output on a machine which operates quietly with the minimum of wear.

Perfect combination of the most modern control technology and mechanical drive components (such as computer-calculated drive cams) as well as an automatic central lubrication system ensure long life and outstanding production results.

The concept of the FA 35 series is based on the FAWEMA rack transport system. We eliminate possible problems which may arise due to the abrasiveness of certain products, by (amongst other constructive measures) separating the drive elements and the product handling area.

Due to the linear construction, the entire packaging process can be monitored from one vantage point.

A suitable closing machine can be integrated into the FAWEMA system upon request.

Outstanding Features

Great Flexibility through:

- quick and easy format change
- easy operation as well as user-friendly programming
- various output levels
- comprehensive range of application for products and packaging materials

Universal Applications by:

- use of different types of filler such as weighers and volumetric fillers
- choice of different types of closure such as upright or flat closure using hot-melt, hot air, heat-sealing, label application or a combination of the above
- robust mechanical construction for high output in multishift

First-class Bags due to:

- effective product settling achieved by a vibration track adjustable in frequency and amplitude
- precise pre-folding and integrated folding station
- effective de-aeration during pre-folding

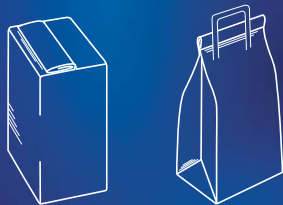

FAWEMA



TECHNICAL DATA: FA 35/35.2/35.3

Weight-range: FA 35: 1 to 15 kg
FA 35.2: 0.5 to 5 kg
FA 35.3: 0.5 to 1 kg

Output: FA 35: 15 to 40 Bags/Minute
FA 35.2: 40 to 80 Bags/Minute
FA 35.3: 15 to 120 Bags/Minute

Bag Sizes: FA 35: 100 x 60 x 250 mm min.
350 x 155 x 700 mm max.
FA 35.2: 100 x 60 x 250 mm min.
170 x 120 x 500 mm max.
FA 35.3: 60 x 25 x 160 mm min.
115 x 80 x 380 mm max.

Application: dry, free-flowing, granular,
and piece products

Typical Examples: sugar, rice, flakes, charcoal,
catlitter, pulses ...

PACK TYPES, MATERIALS

- pre-made bags
- block-bottom bags, folded-bottom bags
or side-gusseted bags
- laminates or mono-material
- single- or multi-ply bags
- low material strengths
- all types of closure
- with or without carrier handles

FA 35

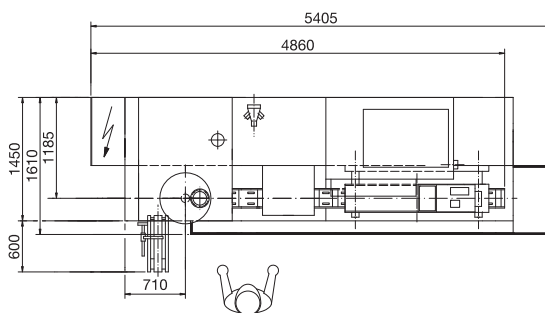

FA 35.2

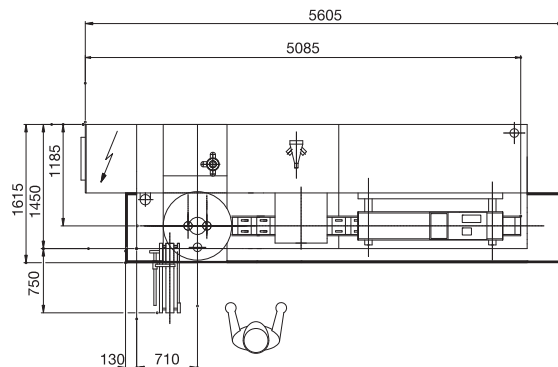

FA 35.3

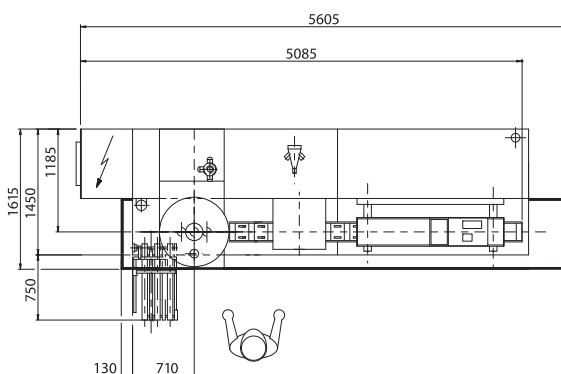

FAWEMA

FAWEMA Maschinenfabrik GmbH & Co. KG, Germany

Wallefelder Straße, D-51766 Engelskirchen-Ründeroth
Tel.: +49 (0) 22 63 / 7 16 - 0, Fax: +49 (0) 22 63 / 7 16 - 6 26
e-mail: info@fawema.com, www.fawema.com

FAWEMA

FA 35

← FA 35.2

FA 35.3

